

VIBRATING SCREENS – STANDARD MODELS

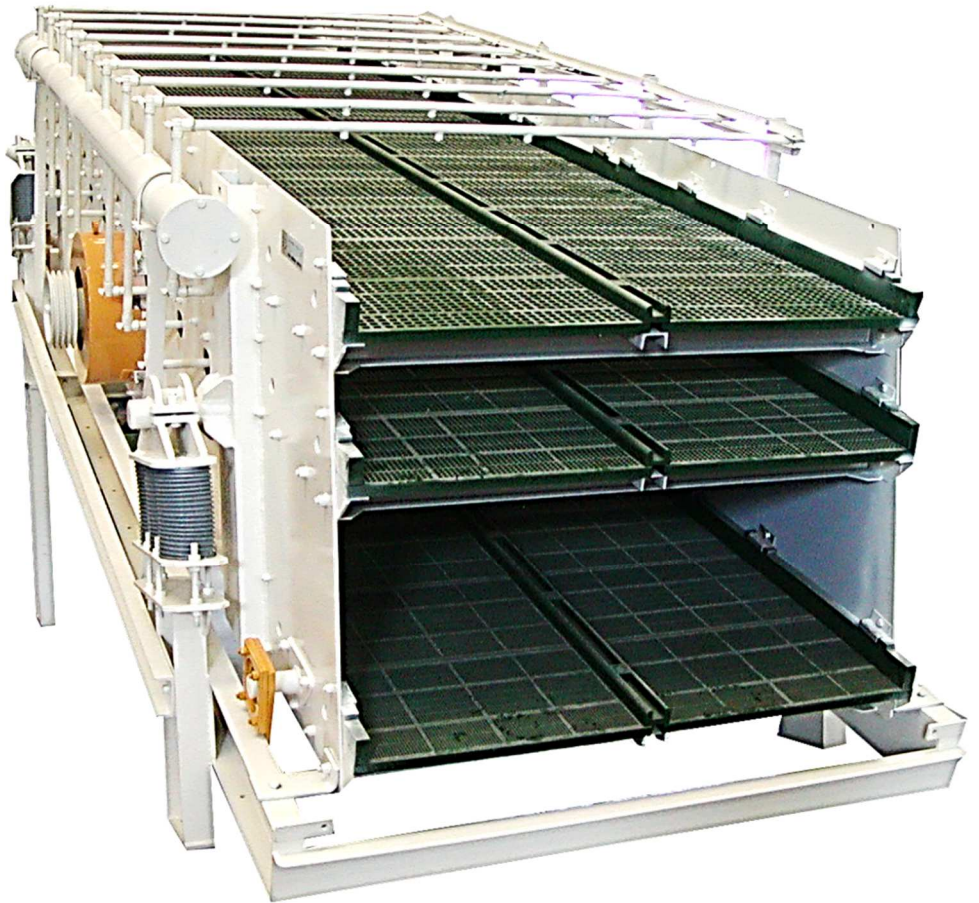
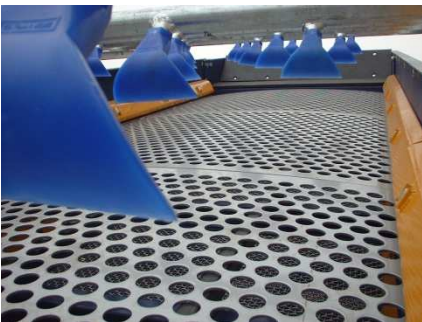

STANDARD SIZES FOR VIBRATING SCREENS VV SERIES

SCREEN TYPE	DECK DIMENSIONS mm	DECK NUMBERS	SCREENING SURFACE mq	APPROX. CAPACITY mc/h	POWER SUPPLY KW	WEIGHT KG
VV252	1000 x 2500	2	2,5	15-25	2,2	1230
VV302	1000 x 3000	2	3	18-30	2,2	1640
VV303	1000 x 3000	3	3	18-30	3	2035
VV362	1200 x 3000	2	3,6	21-35	3	2150
VV363	1200 x 3000	3	3,6	21-35	4	2600
VV482	1200 x 4000	2	4,8	30-50	4	2475
VV483	1200 x 4000	3	4,8	30-50	5,5	3100
VV602	1500 x 4000	2	6	35-60	5,5	3500
VV603	1500 x 4000	3	6	35-60	7,5	4350
VV752	1500 x 5000	2	7,5	40-75	7,5	3950
VV753	1500 x 5000	3	7,5	40-75	11	4570
VV902	1800 x 5000	2	9	60-90	11	5150
VV903	1800 x 5000	3	9	60-90	15	6400
VV1082	1800 x 6000	2	10,8	70-110	15	5725
VV1083	1800 x 6000	3	10,8	70-110	22	7200
VV1262	2100 x 6000	2	12,6	80-130	22	7300
VV1263	2100 x 6000	3	12,6	80-130	30	8800

TECHNICAL FEATURES

Free vibration system obtained by an oscillator with adjustable **eccentric mass shaft** operating on roller bearings sized for a theoretical life exceeding 20,000 hours, with **grease or alternatively oil bath lubrication**. The electric motor is connected through V-belts appropriately protected; the drive pulley is characterized by compensated eccentricity to minimize the flapping of the belts. The elastic suspension is obtained by steel springs sized to dampen the vibration by more than eighty percent. The frames of the decks are robust and are mounted to the sides with self-locking bolts; to allow the optional assembly of screening nets of different types (steel nets, perforated sheets, rubber nets, polyurethane panels, etc.), the central support rails are fixed to the frame crossbars through self-locking bolts, so as to permit the replacement with more appropriate models. The deck supporting walls are always provided with holes for side tension anchor bolts; the central longitudinal supports are equipped with wear-resistant rubber seals.

It is possible to apply a **shower system** to wash the screened products; it is also possible to apply a cover for **dust suction**.

The empty weight screen produces extremely low noise; at full load, the noise level depends on the different nature of the material treated.

Decca Impianti can dimension and realize the range of screens for all requirements; the data which are necessary for the calculation of the most suitable kind of screen are:

- capacity (t/h)
- max. size and granulometric curve of the material to be treated (mm)
- number of desired selections and related sizes (mm)
- characteristics of the material to screen (type, specific gravity, humidity and temperature)
- plant system (with or without washing system, covered or uncovered screen, ambient humidity and temperature)

Equipment:

- inclined support frame
- elastic supports on steel springs with safety protections
- screening nets of various types
- electric motor MEC IP 55 V.380 Hz 50 sealed series
- belt transmission with safety shields in accordance with the law
- belt tensioning and motor fixing sleds

OVERALL DIMENSIONS OF STANDARD SCREENS INCLINED AT 18 ° (other possible inclinations 15° and 21°)

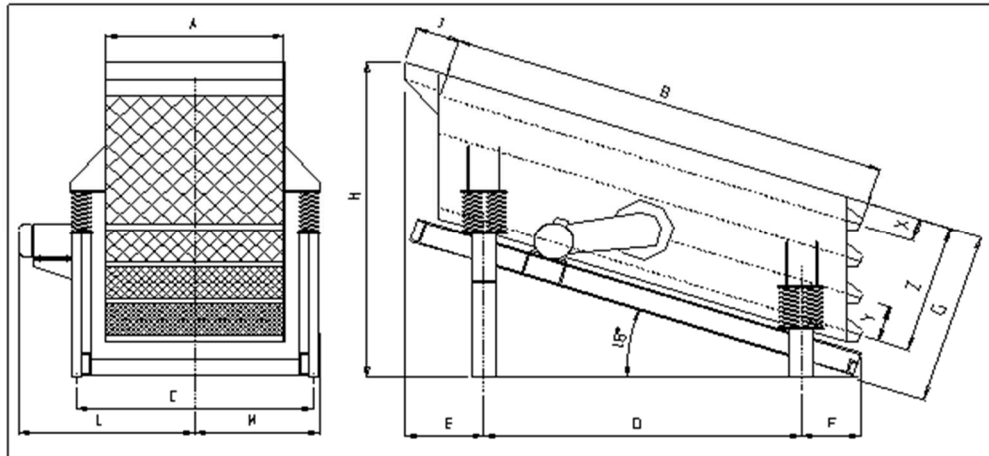

SCREEN*	A	B	C	D	E	F	G	H	I	L	M	X	Y	Z
VV252	1000	2500	1380	1780	460	460	1000	1980	400	990	790	250		820
VV302	1000	3000	1380	2230	460	460	1000	2155	400	990	800	250		820
VV303	1000	3000	1380	2230	460	460	1270	2390	400	1040	820	250	250	1090
VV362	1200	3000	1580	2230	460	460	1020	2000	400	1140	920	250		850
VV363	1200	3000	1580	2230	460	460	1260	2240	400	1190	930	250	250	1090
VV482	1200	4000	1580	2450	790	800	1070	2600	400	1190	930	250		850
VV483	1200	4000	1580	2450	790	800	1320	2840	400	1250	940	250	250	1120
VV602	1500	4000	1875	2450	790	800	1070	2600	500	1400	1090	250		870
VV603	1500	4000	1875	2450	790	800	1320	2840	500	1530	1110	250	250	1120
VV752	1500	5000	1875	3350	940	800	1240	2880	500	1530	1110	250		870
VV753	1500	5000	1875	3350	940	800	1520	3230	500	1570	1130	250	250	1190
VV902	1800	5000	2100	3350	940	800	1260	2900	500	1690	1250	300		950
VV903	1800	5000	2100	3350	940	800	1610	3250	500	1750	1250	300	300	1300
VV1082	1800	6000	2100	4500	1040	900	1320	3100	500	1750	1250	300		1000
VV1083	1800	6000	2100	4500	1040	900	1770	3530	500	1880	1250	300	300	1450
VV1262	2100	6000	2400	4500	1040	900	1470	3400	500	1880	1400	300		1150
VV1263	2100	6000	2400	4500	1040	900	1770	3690	500	2000	1400	300	300	1450

* The models shown are standards that can be adapted and modified according to specific customer needs.