

## VIBRATING SAND DRYER "VA" SERIES

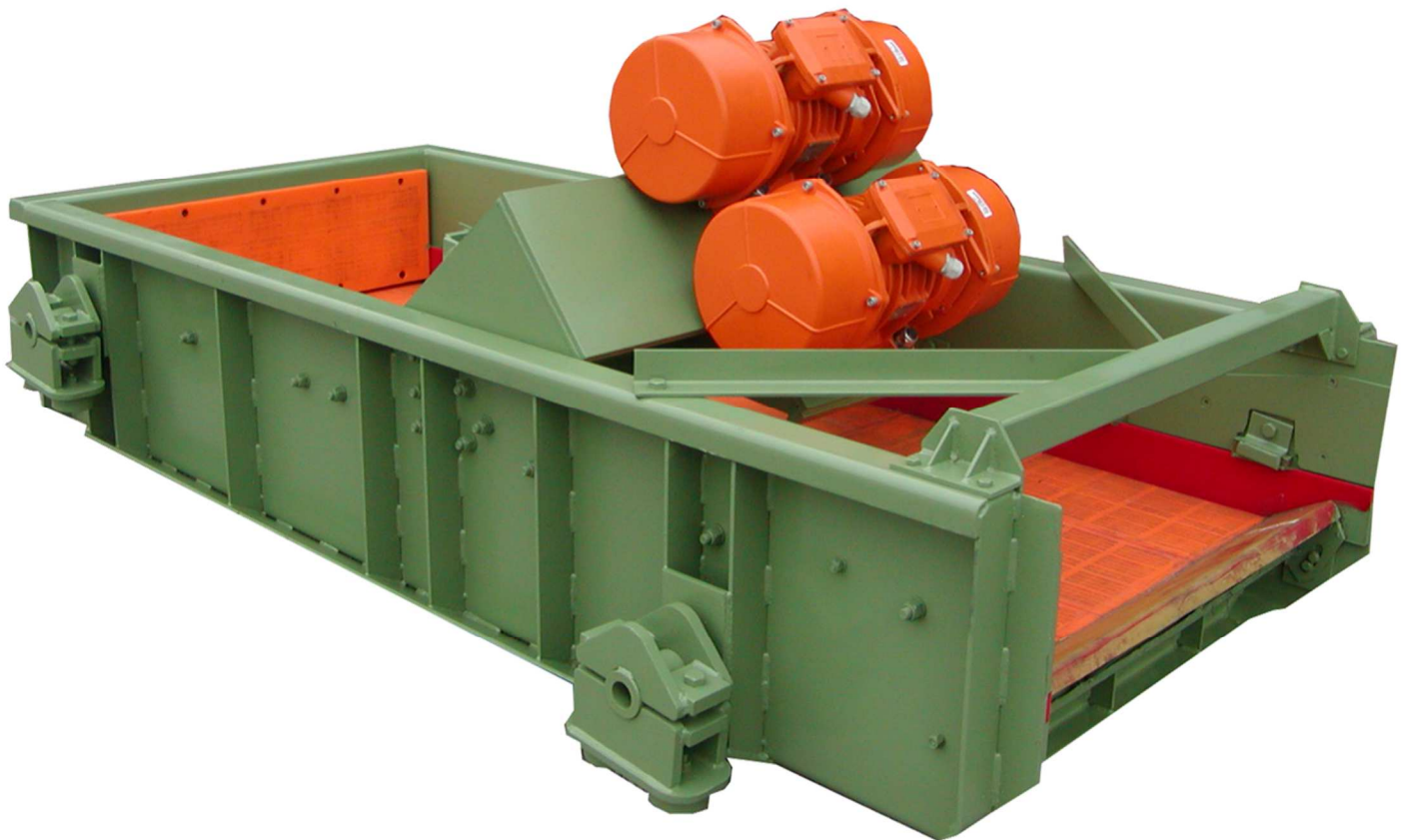

### IDEAL TO REMOVE HUMIDITY FROM SANDS

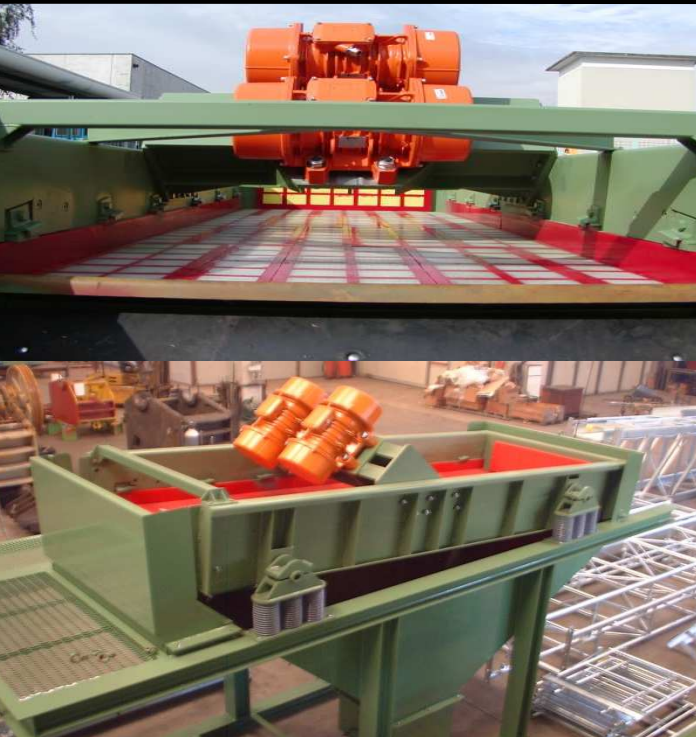

The use of vibrating dryers of the "VA" series guarantees:

- a constant speed of material advancement;
- the possibility of changing the transport speed by adjusting the balance of the vibrator motion:
- a substantial reduction in water content;
- the ability to retain valuable particles.

## TECHNICAL FEATURES

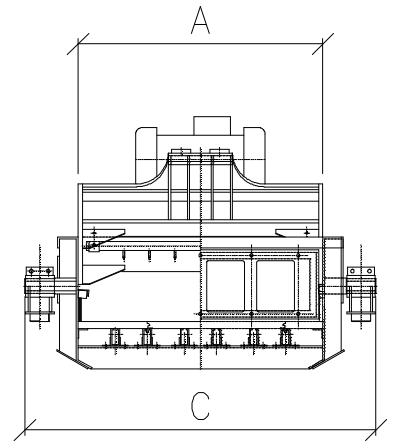
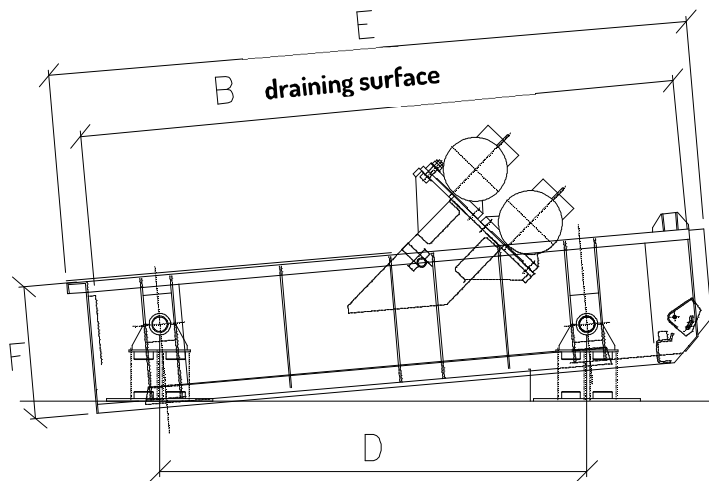

TYPE*	A (mm)	B (mm)	C (mm)	D (mm)	E (mm)	F (mm)	weight (Kg)	motovibrator power supply (Kw)
VA 100	675	1800	1100	1300	2286	560	700	1,5 + 1,5
VA 200	1150	1800	1650	1300	2306	620	1050	2,2 + 2,2
VA 300	1150	2700	1650	2000	3006	620	1420	3,6 + 3,6
VA 500	1325	3600	1850	2900	3906	720	2070	6,0 + 6,0
VA 700	1475	4500	2050	3600	4846	820	2880	9 + 9

TYPERS*	sand capacity (max) m <sup>3</sup> /h	water capacity (max) m <sup>3</sup> /h	flow speed m/s	layer thickness mm
VA 100	20	25	0,165	50
VA 200	35	40	0,17	50
VA 300	53	60	0,17	75
VA 500	81	90	0,17	100
VA 700	112	125	0,17	125

\* The models shown are standards that can be adapted and modified according to specific customer needs.